

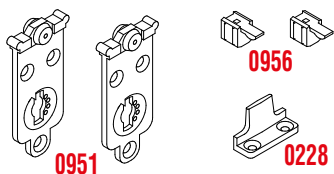



## KIT 0951 AC - MAX 15 KG



### Legenda KIT / Kit Legend

<b>0951</b>	Carrello 2 ruote senza giunto eccentrico <i>Truck with 2 rollers without eccentric joint</i>
<b>0956</b>	Fermo superiore <i>Upper stopper</i>
<b>0228</b>	Scivolo inferiore <i>Lower slide</i>

### Legenda altri componenti Legend other items

<b>0950</b>		Profilo alluminio superiore <i>Upper aluminium profile</i>
-------------	---	---

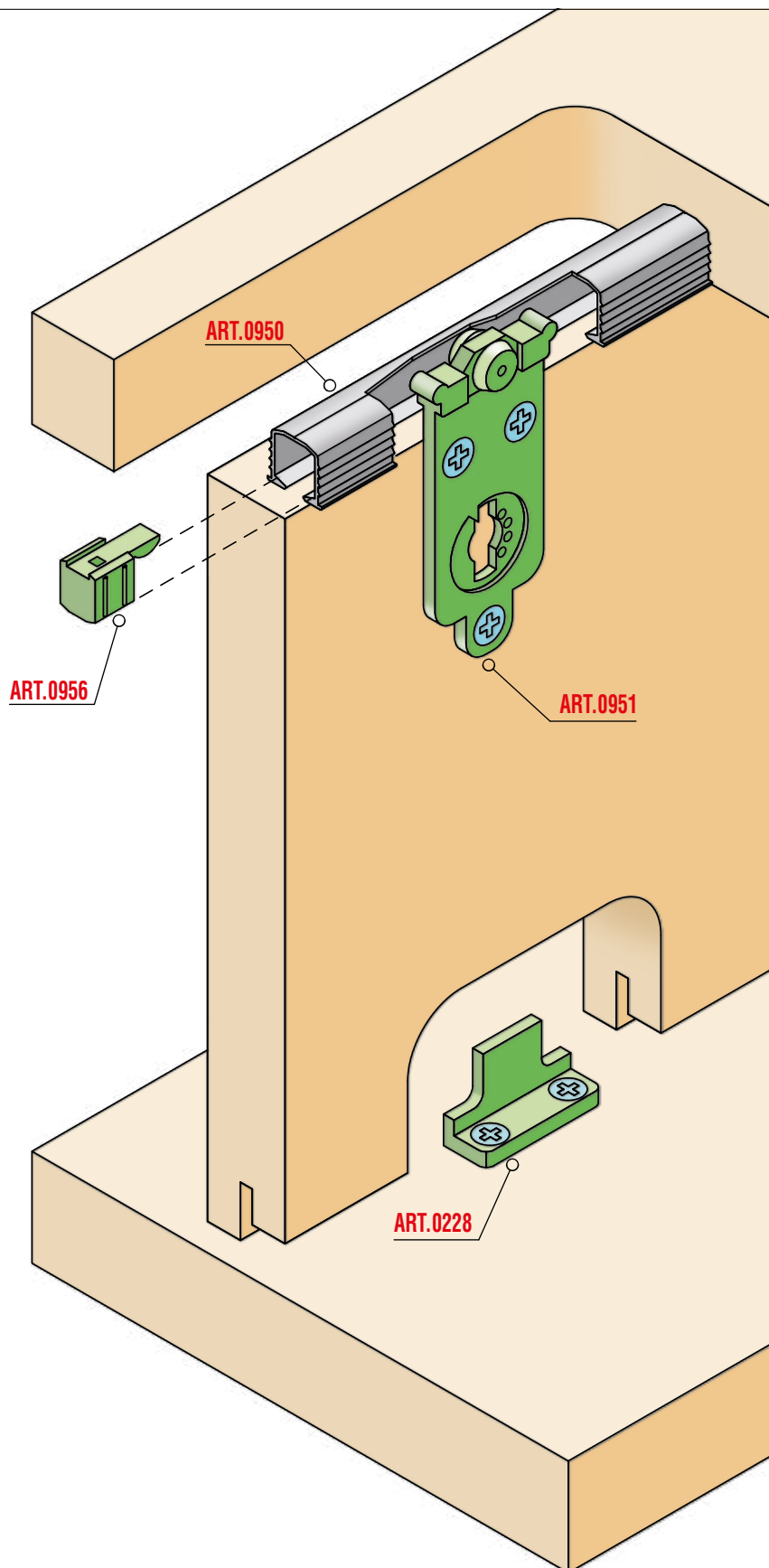



## Sezione verticale / Vertical section

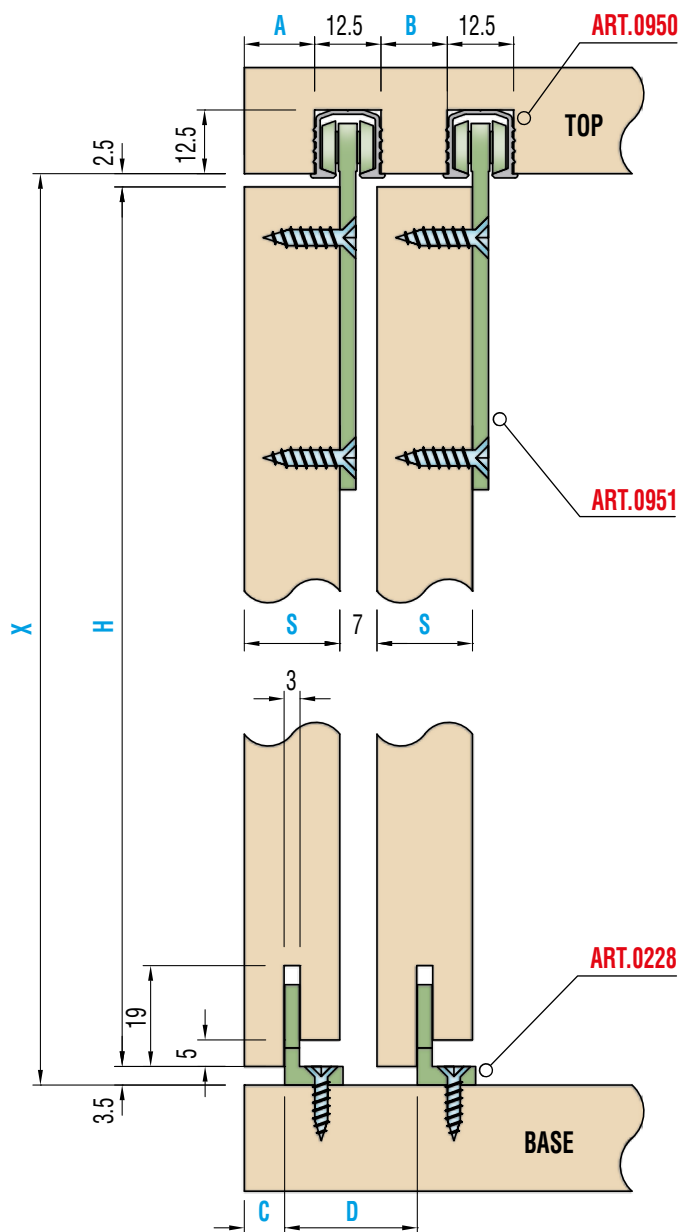

Peso massimo anta Kg. 15  
Maximum door weight Kg 15

Regolazione massima verticale 2 mm.  
Maximum vertical adjustment 2 mm.

H =	X - 6
A =	S* - 4,5
B =	S* - 5,5

C =	S/2 - 1,5
D =	S* + 7

S\* (spessore / thickness)  
min.18

## Schema Foratura ante / Doors drilling

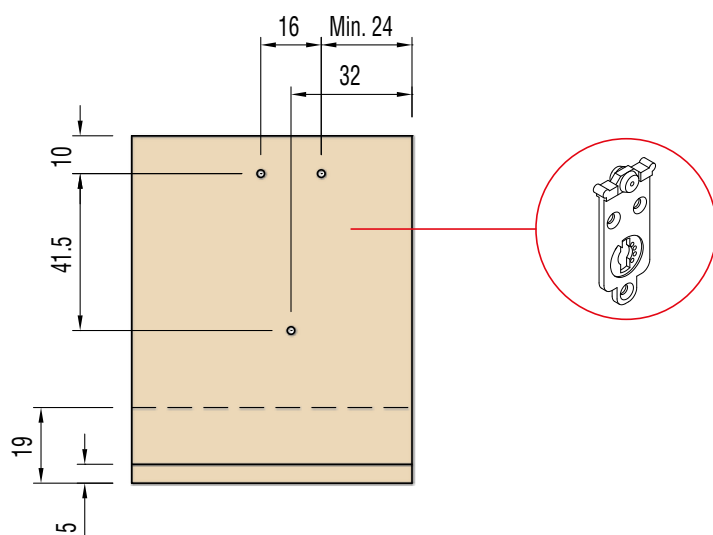

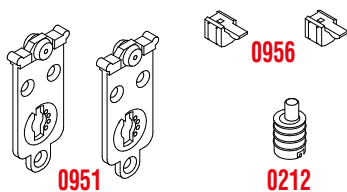

## KIT 0951 AC-212 - MAX 15 KG



### Legenda KIT / Kit Legend

<b>0951</b>	Carrello 2 ruote senza giunto eccentrico <i>Truck with 2 rollers without eccentric joint</i>
<b>0956</b>	Fermo superiore <i>Upper stopper</i>
<b>0212</b>	Guida inferiore eccentrica <i>Lower eccentric runner</i>

### Legenda altri componenti Legend other items

<b>0950</b>		Profilo alluminio superiore <i>Upper aluminium profile</i>
<b>0211</b>		Profilo plastica inferiore <i>Lower plastic profile</i>

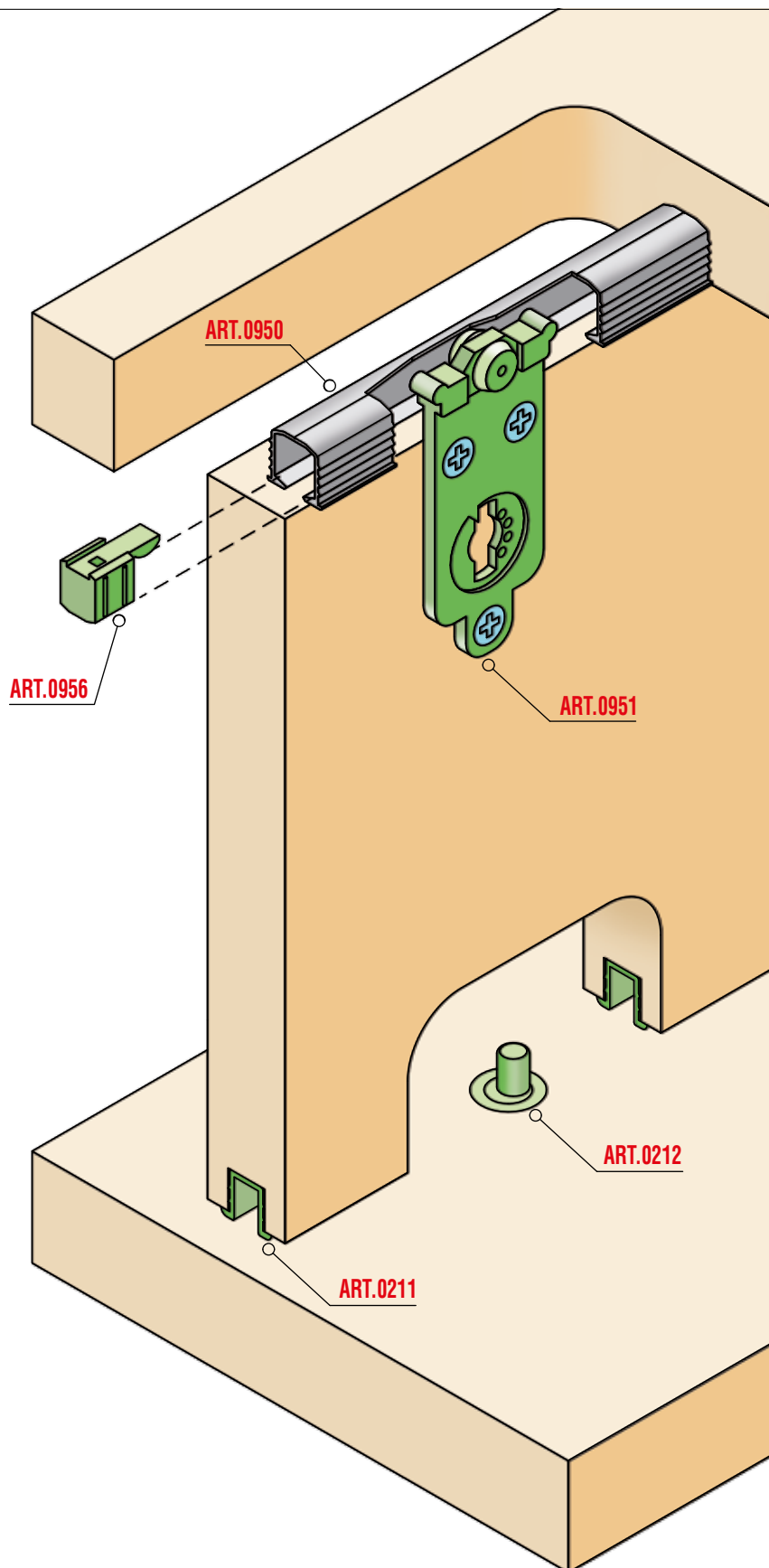



## Sezione verticale / Vertical section

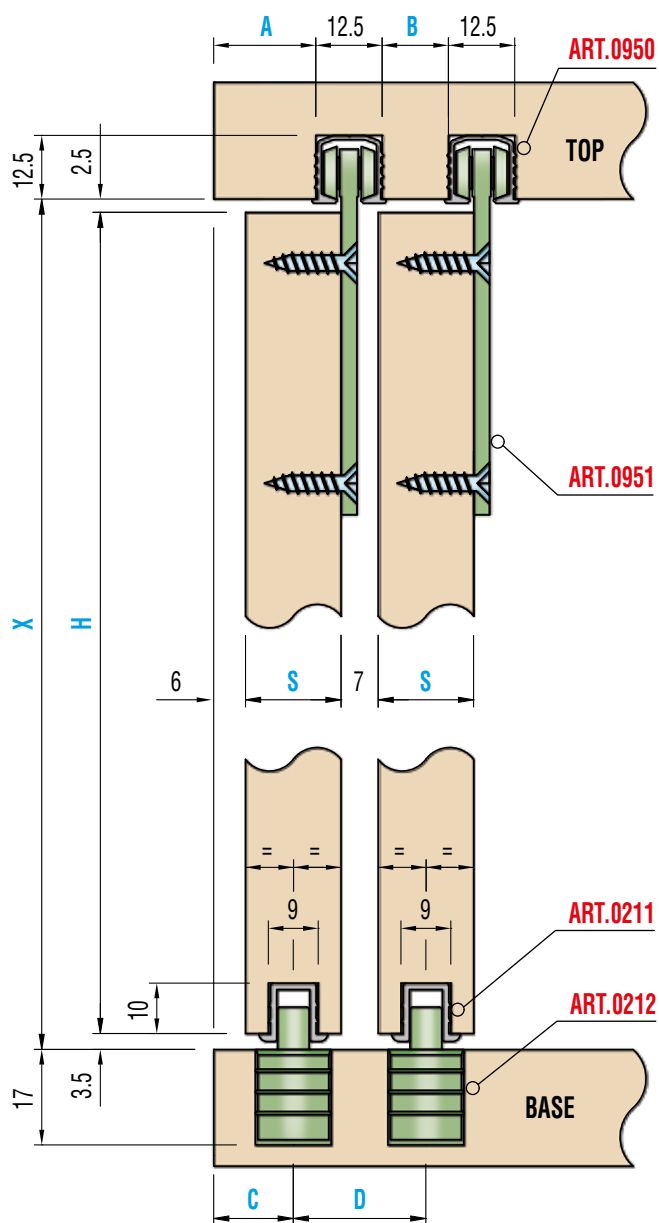

Peso massimo anta Kg. 15  
Maximum door weight Kg 15

Regolazione massima verticale 2 mm.  
Maximum vertical adjustment 2 mm.

H =	X - 6
A =	S* + 1,5
B =	S* - 5,5

C =	S/2 + 6
D =	S* + 7

S\* (spessore / thickness)  
min.18

## Schema Foratura ante / Doors drilling

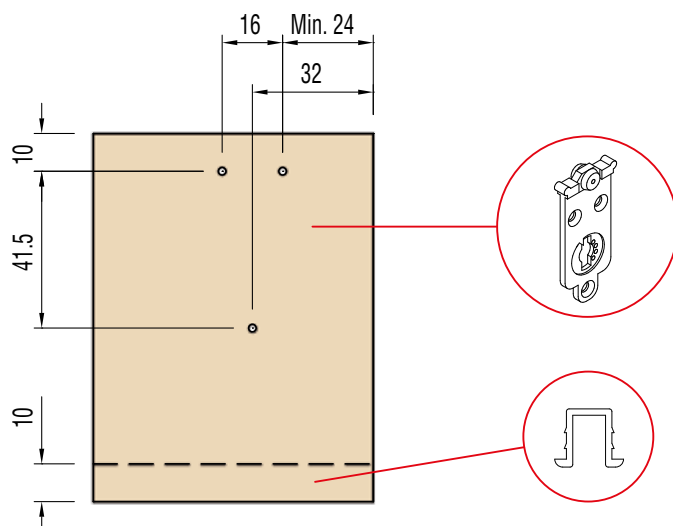

## Schema di montaggio / Assembling

1

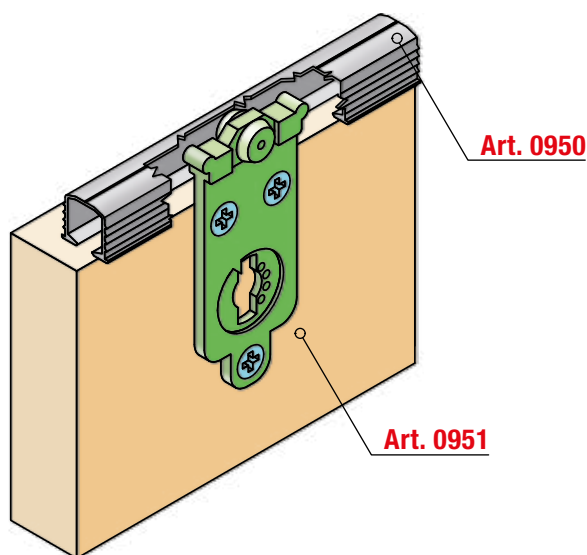

### 1 MONTAGGIO CON CARRELLO SENZA GIUNTO ECCENTRICO

Introdurre i fermi ART.0956 ed i carrelli superiori ART.0951 all'interno del profilo ART.0950. Inserire il profilo ART.0950 nella sede precedentemente creata sul top del mobile. Infine avvitare i carrelli ART.0951 sull'anta.

### 1 ASSEMBLING WITH TRUCK WITHOUT ECCENTRIC JOINT

Insert the stoppers ART.0956 and the upper trucks ART.0951 into the profile ART.0950.

Fit the profile ART.0950 to the seat previously prepared on the furniture top and screw the trucks ART.0951 to the door.

0950	Profilo alluminio superiore
	Upper aluminium profile

0951	Carrello 2 ruote senza giunto eccentrico
	Truck with 2 rollers without eccentric joint

2

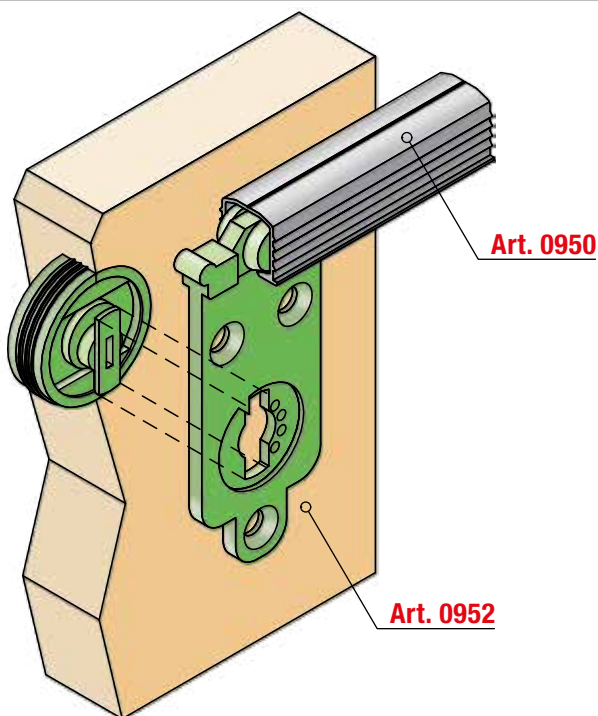

### 2 MONTAGGIO CON CARRELLO CON GIUNTO ECCENTRICO

Introdurre i fermi ART.0956 ed i carrelli superiori ART.0952 all'interno del profilo ART.0950. Inserire il profilo ART.0950 nella sede precedentemente creata sul top del mobile. Montare i giunti eccentrici sull'anta, poi fissare i giunti sui carrelli ART.0952.

### 2 ASSEMBLING WITH TRUCK WITH ECCENTRIC JOINT

Insert the stoppers ART.0956 and the upper trucks ART.0952 into the profile ART.0950. Fit the profile ART.0950 to the seat previously prepared on the furniture top. Fit the eccentric joints to the door, then fix them to the trucks ART.0952.

0950	Profilo alluminio superiore
	Upper aluminium profile

0952	Carrello 2 ruote con giunto eccentrico
	Truck with 2 rollers with eccentric joint

3

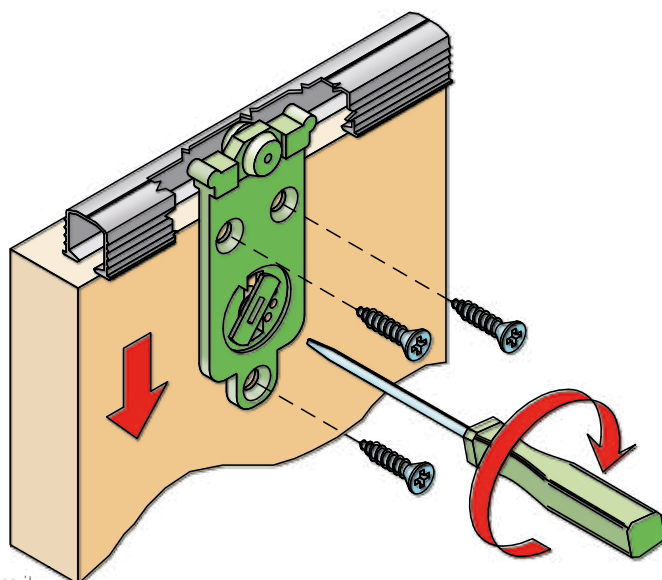

3 Bloccare l'anta ruotando fino al primo scatto il giunto eccentrico e, se necessario, regolare l'anta ruotando ancora il giunto eccentrico in senso orario. Dopo aver regolato l'anta nella corretta posizione, bloccare il carrello con delle viti.

3 Lock the door by turning the eccentric joint to the first bore and, if necessary, adjust the door by turning again the eccentric joint clockwise. After adjusting the door to the right position, screw the truck.